

## Low VF Bridge Rectifiers

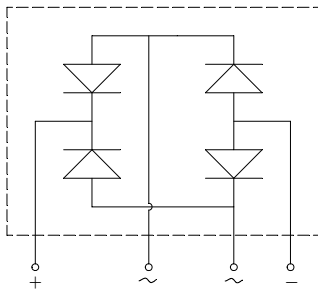

### Features

- UL recognition, file #E230084
- Glass passivated chip junction
- Low VF
- Thin single in-line package
- High surge current capability
- Solder dip 275 °C max. 7 s, per JESD 22-B106

### Typical Applications

General purpose use in AC/DC bridge full wave rectification for switching power supply, home appliances, office equipment, industrial automation applications.

### Mechanical Data

- **Package:** JB  
Molding compound meets UL 94 V-0 flammability rating, RoHS-compliant, Halogen free
- **Terminals:** Tin plated leads, solderable per J-STD-002 and JESD22-B102
- **Polarity:** As marked on body

### ■ Maximum Ratings ( $T_a=25^\circ\text{C}$ Unless otherwise specified)

PARAMETER	SYMBOL	UNIT	D8JBL80S	
Device marking code			D8JBL80S	
Maximum Repetitive Peak Reverse Voltage	VRRM	V	800	
Maximum RMS Voltage	VRMS	V	560	
Maximum DC blocking Voltage	VDC	V	800	
Average Rectified Output Current @60Hz sine wave, R-load,	With heatsink $T_c = 105^\circ\text{C}$	IO	A	8.0
	Without heatsink $T_a = 25^\circ\text{C}$			3.2
Forward Surge Current (Non-repetitive) @60Hz Half-sine wave, 1 cycle, $T_j=25^\circ\text{C}$	IFSM	A	175	
Forward Surge Current (Non-repetitive) @1ms, square wave, 1 cycle, $T_j=25^\circ\text{C}$			350	
Current squared time @1ms $\leq t \leq 8.3$ ms $T_j=25^\circ\text{C}$ , rating of per diode	$I^2t$	A <sup>2</sup> S	127	
Storage temperature	Tstg	°C	-55 ~ +150	
Junction temperature	Tj	°C	-55 ~ +150	
Dielectric strength @ Terminals to case, AC 1 minute	Vdis	KV	2	
Mounting torque @Recommend torque: 5kg·cm	Tor	kg·cm	8	



# D8JBL80S

## ■ Electrical Characteristics (T<sub>a</sub>=25°C Unless otherwise specified)

PARAMETER	SYMBOL	UNIT	TEST CONDITIONS	D8JBL80S
Maximum instantaneous forward voltage drop per diode	V <sub>F</sub>	V	IFM=4.0A	0.92
Maximum DC reverse current at rated DC blocking voltage per diode	I <sub>R</sub>	μA	T <sub>j</sub> =25°C	5
			T <sub>j</sub> =125°C	100
Typical junction capacitance	C <sub>j</sub>	pF	Measured at 1MHz and Applied Reverse Voltage of 4.0 V.D.C	55

## ■ Thermal Characteristics (T<sub>a</sub>=25°C Unless otherwise specified)

PARAMETER		SYMBOL	UNIT	D8JBL80S
Thermal Resistance	Between junction and ambient, Without heatsink	R <sub>θJ-A</sub>	°C/W	28.0
	Between junction and case, With heatsink	R <sub>θJ-C</sub>		2.8

Note: Device mounted on 75mm x 45mm x 5.5mm Aluminum Plate Heatsink.

## ■ Ordering Information (Example)

PREFERRED P/N	PACKAGE CODE	UNIT WEIGHT(g)	MINIMUM PACKAGE(pcs)	INNER BOX QUANTITY(pcs)	OUTER CARTON QUANTITY(pcs)	DELIVERY MODE
D8JBL80S	B1	Approximate 2.4	20	900	1800	Tube

## ■ Characteristics(Typical)

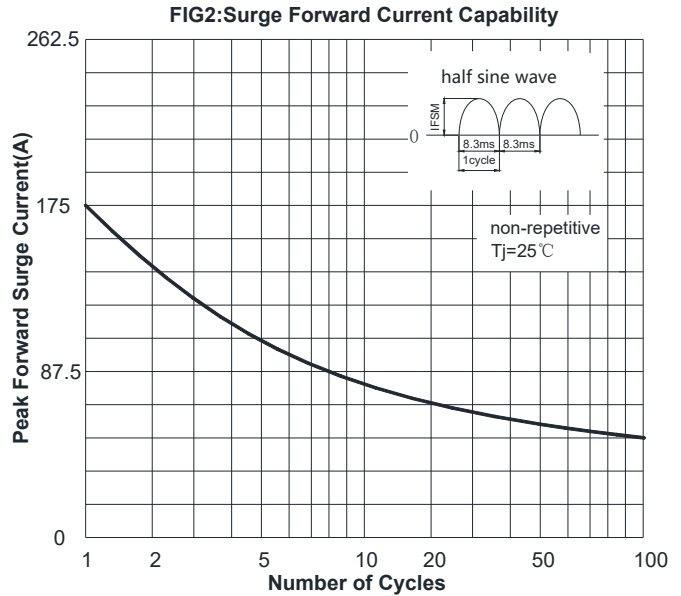
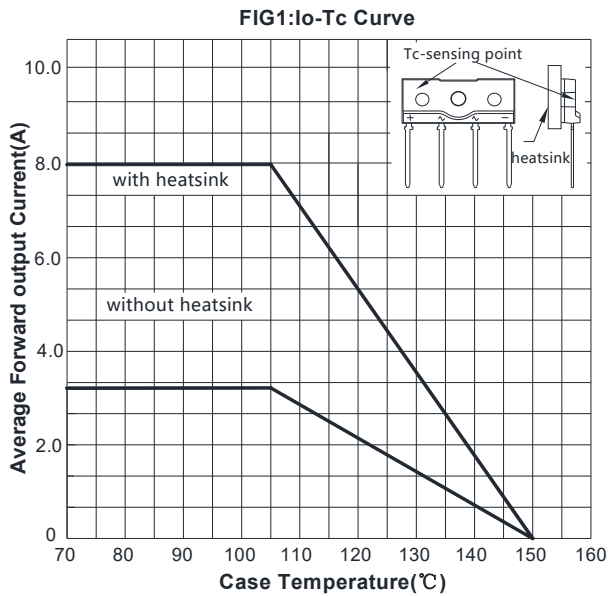

FIG3: Typical Forward Voltage

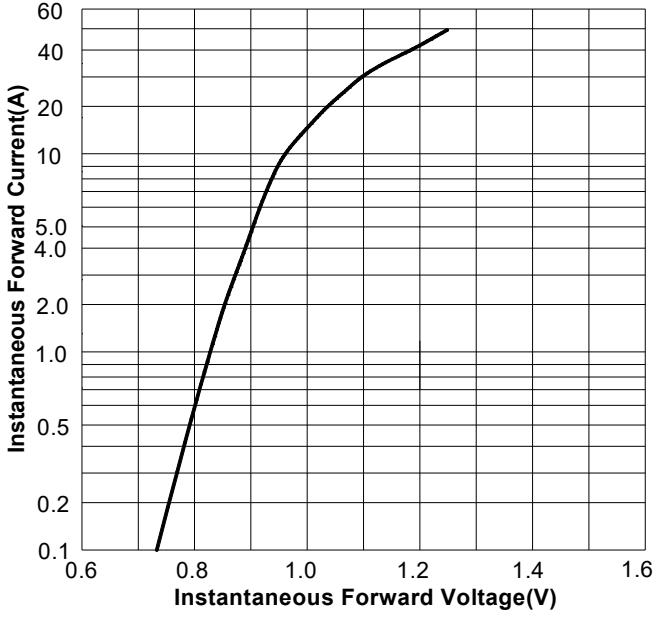
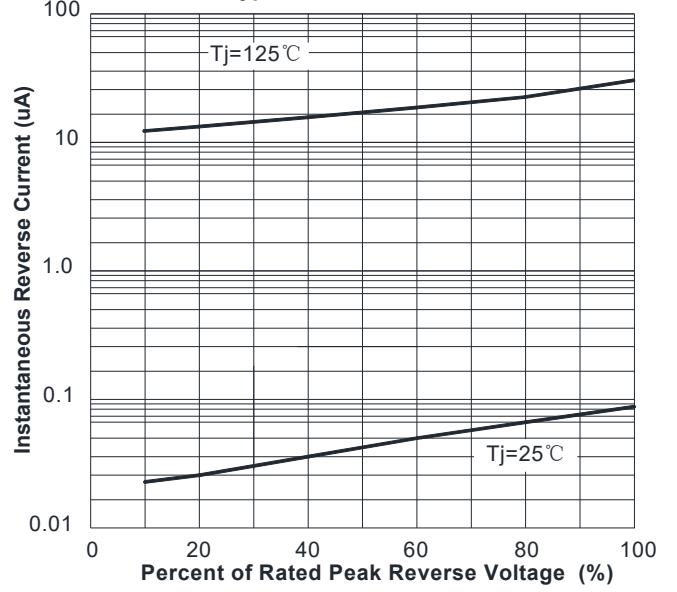
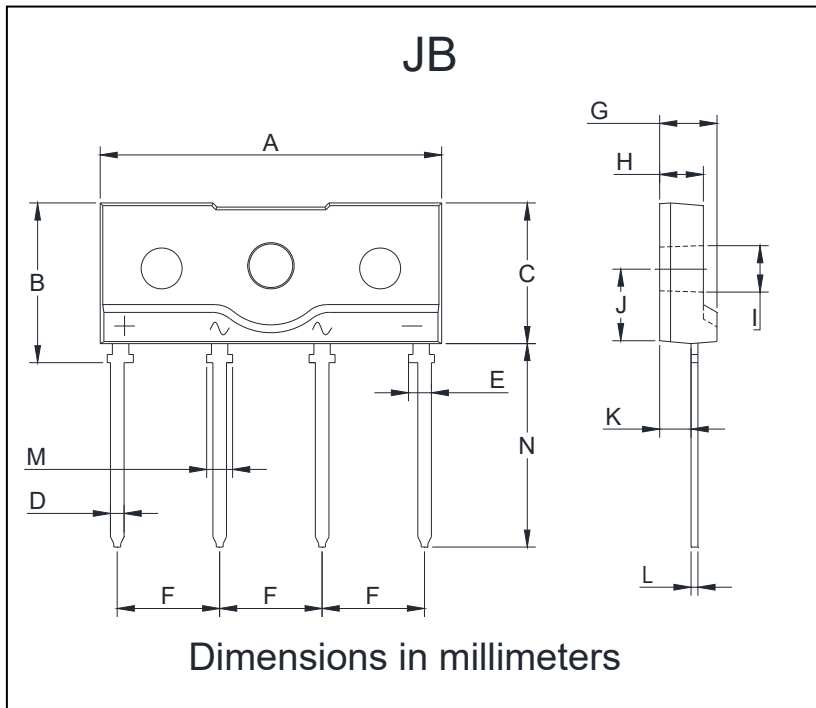

FIG4: Typical Reverse Characteristics



## Outline Dimensions



JB		
Dim	Min	Max
A	24.7	25.3
B	11.4	12.0
C	10.0	10.6
D	0.9	1.1
E	1.75(MAX)	
F	7.3	7.7
G	3.9	4.5
H	2.9	3.9
I	3.1	3.4
J	5.4	6.0
K	2.0	2.6
L	0.4	0.6
M	2.1	2.3
N	14.6	15.2



## D8JBL80S

---

### Disclaimer

The information presented in this document is for reference only. Yangzhou Yangjie Electronic Technology Co., Ltd. reserves the right to make changes without notice for the specification of the products displayed herein to improve reliability, function or design or otherwise.

The product listed herein is designed to be used with ordinary electronic equipment or devices, and not designed to be used with equipment or devices which require high level of reliability and the malfunction of which would directly endanger human life (such as medical instruments, transportation equipment, aerospace machinery, nuclear-reactor controllers, fuel controllers and other safety devices), Yangjie or anyone on its behalf, assumes no responsibility or liability for any damages resulting from such improper use of sale.

This publication supersedes & replaces all information previously supplied. For additional information, please visit our website [http:// www.21yangjie.com](http://www.21yangjie.com) , or consult your nearest Yangjie's sales office for further assistance.